



-  3 membrane semidrauliche, collettori esterni in acciaio inox, testate in ottone, comando disponibile a distanza o valvola di regolazione incorporata.
-  3 diaphragms semi-hydraulic, external manifolds in stainless steel, brass heads, remote control assembly or incorporated regulating valve.
-  3 membranes semi-hydrauliques, collecteurs à l'extérieur du carter en acier inox, culasse en laiton. Groupe de commande seulement à distance.
-  Pumpe in Sternbauweise mit 3 Kolbenmembranen, halbhydraulisch gestützt. Aussen, liegende Saugdruckkanäle und für Fernbedienungsarmatur vorgesehen. Flüssigkeitsführende Teile aus rostbeständigem Material.
-  3 membranas semi-hidráulicas, colectores externos, partes en contacto con líquidos en material anticorrosión. Mando a distancia.
-  3 полугидравлические мембраны, внешние коллекторы и головки обработанные методом катафорезы, регуляторы возможны только на расстоянии, части находящиеся в контакте с жидкостями сделаны из нержавеющей материала.



# IPB 150

**IMPIEGHI**  
Irrorazione,  
Atomizzatori

**APPLICATIONS**  
Spraying,  
Mistblowers

**EMPLOIS**  
Pulvérisation,  
Atomiseurs

**VERWENDUNGEN**  
Spritzen,  
Sprühgeräte

**APLICACIONES**  
Pulverización,  
Atomizadores

**ИСПОЛЬЗОВАНИЕ**  
Опрыскивание,  
Распыление

	Pressione - Pressure - Pression - Druck - Presión - Давление																				
	10 bar / 145 PSI				20 bar / 290 PSI				30 bar / 435 PSI				40 bar / 580 PSI				50 bar / 725 PSI				
	Portata Delivery Débit Foerderleistung Caudal Поддача		Potenza Power Puissance Leistung Potencia Мощность		Portata Delivery Débit Foerderleistung Caudal Поддача		Potenza Power Puissance Leistung Potencia Мощность		Portata Delivery Débit Foerderleistung Caudal Поддача		Potenza Power Puissance Leistung Potencia Мощность		Portata Delivery Débit Foerderleistung Caudal Поддача		Potenza Power Puissance Leistung Potencia Мощность		Portata Delivery Débit Foerderleistung Caudal Поддача		Potenza Power Puissance Leistung Potencia Мощность		
	RPM	l/min.	US GPM	HP	KW	l/min.	US GPM	HP	KW	l/min.	US GPM	HP	KW	l/min.	US GPM	HP	KW	l/min.	US GPM	HP	KW
<b>350</b>	96	26	3,5	2,6	95	25	5,6	4,1	94	25	7,7	5,6	93	24	9,7	7,1	92	24	11,7	8,6	
<b>400</b>	107	28	3,9	2,9	106	28	6,3	4,6	105	27	8,6	6,3	104	27	10,8	8,0	103	26	13,0	9,6	
<b>450</b>	119	31	4,2	3,2	118	31	7,0	5,1	117	30	9,6	7,0	116	30	12,1	8,9	115	29	14,6	10,7	
<b>500</b>	132	35	4,8	3,5	131	35	7,7	5,7	130	34	10,6	7,8	129	34	13,5	9,9	128	33	16,3	12,0	
<b>550</b>	143	38	5,2	3,8	142	37	8,4	6,2	141	37	11,5	8,5	140	36	14,6	10,7	140	36	17,8	13,1	

Giri/1': max 550  
Pressione: max 50 bar  
Portata: max 143 l/1'  
Peso Kg 52  
Max disl. Asp.: 3m

Max RPM: 550  
Pressure: max 50 bar  
Capacity: max 143 l/1'  
Weight: Kg 52  
Max suction lift: 3m

Tours/1': max 550  
Pression: max 50 bar  
Débit: max 143 l/1'  
Poids: Kg 52  
Max haut. Asp.: 3m

UmdrPro: max 550  
Druck: max 50 bar  
Foerderleistung: max 143 l/1'  
Gewicht: Kg 52  
Max Ansaughöhe: 3m

RPM: max 550  
Presión: max 50 bar  
Caudal: max 143 l/1'  
Peso: Kg 52  
Max disn. Asp.: 3m

Число оборотов: 550  
Давление: 50 бар  
Поддача: 143 л/Мин  
Вес: Кг 52  
Макс. Глубина. Всасыв.: 3 м

# IPB 150

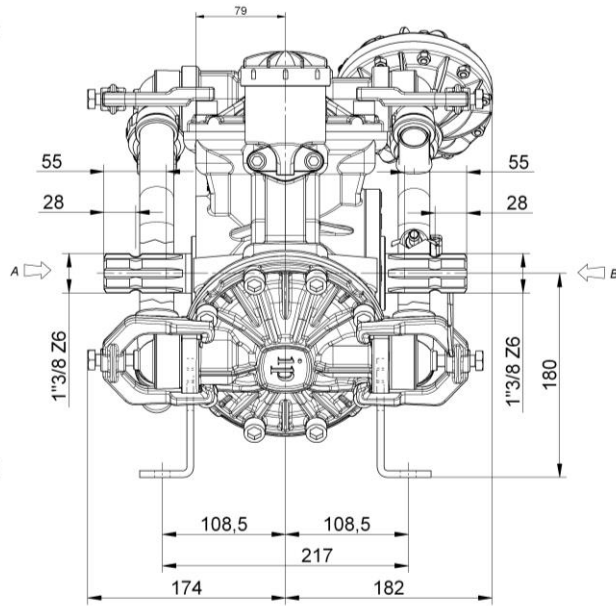
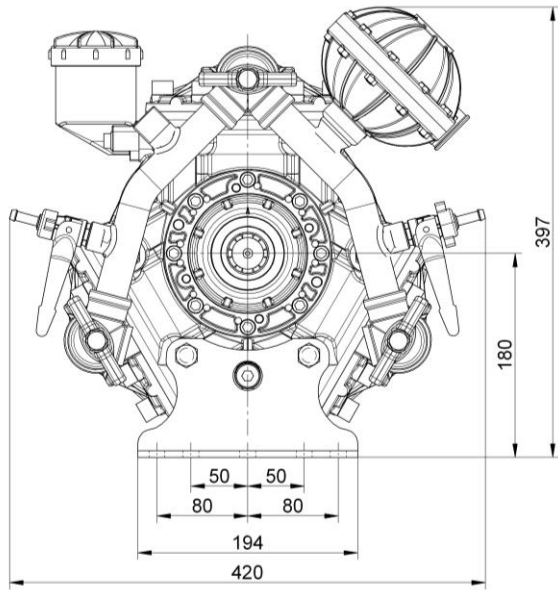

- Basi rigide su 4 punti
- Reinforced support frame with 4 fixing screws
- Semelles renforcées avec 4 points de fixation
- Steife Unterlagen mit Befestigung auf 4 Punkte
- Base reforzada con 4 puntos de fijación
- Несгибающиеся базы на 4 пунктах

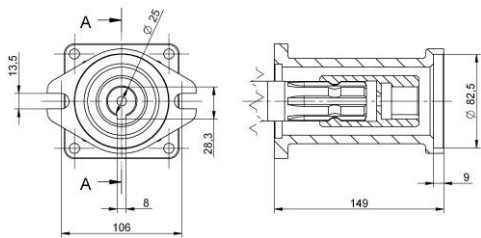
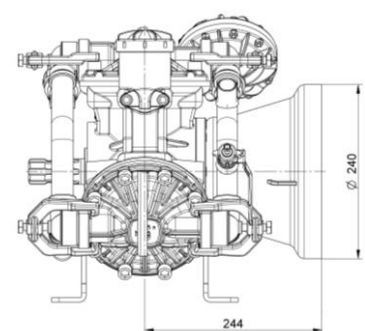
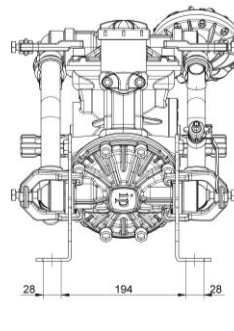
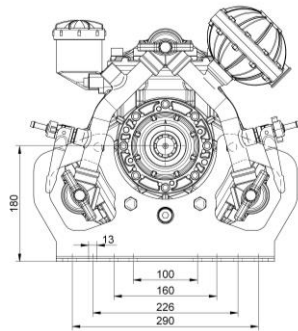

- Kit Flangiatura Mot. Idraulico (solo lato "A")
- Adapter flange kit for hydraulic motor ("A" Only Side)
- Bride pour moteur hydraulique (côté "A" seulement)
- Geflanscht zu Hydromotoren (Nur "A"- Seite)
- Brida para motores hidráulicos (sólo lado "A")
- Набор фланцев для гидравл. мотора (только со стороны A)

- Cuffia protezione cardano
- PTO shaft protection shield
- Bol de protection
- Schutzglocke
- Protector cigüeñal
- Защитная муфта кардана

COMPONENTI	MATERIALI	COMPONENTS	MATERIALS	COMPOSANTS	MATERIAUX	TEILE	MATERIALEN	COMPONENTES	MATERIALES	КОМПОНЕНТЫ	МАТЕРИАЛЫ
carter	ghisa	pump body	cast iron	carter	fonte	Gehäuse	Grauguss	cuerpo bomba	fundición	картер	чугун
testata	ottone	pump head	brass	culasse	laiton	Zylinderkopf	Messing	culata	latón	головка	латунь
collettori	acciaio inox	manifolds	stainless steel	claviatures	acier inox	Saug- druckkanälen	rostfreier Stahl	colectores	acero inox	коллекторы	сталь инокс
valvola A/M	acciaio inox	check valve	stainless steel	clapet asp. ref.	acier inox	Ventil	rostfreier Stahl	válvula A/M	acero inox	нагнетат. клапан	сталь инокс
cappello valvola	resina sintetica	valve cage	synthetic resin	cage du clapet	résine synthétique	Ventilkäfig	Kunstharz	cajera válvula	resina sintética	выпускной клапан	синтетическая смола
membrana	gomma nitrilica	pump diaphragm	nitril rubber	membrane	caoutchouc nitrilique	Membran	Gummi	membrana	goma nitrilica	мембрана	нитрильная резина
albero	acciaio cement. e temprato	pump shaft	casehardened steel	vilebrequin	acier cimenté et trempé	Welle	gehärteter Stahl	cigüeñal	acero cement. y templado	вал	жаропрочная сталь
camera aria	gomma nitrilica	dumper diaphragm	Nitril rubber	chambre à air	caoutchouc nitrilique	Windkessel Membran	Gummi	membrana calderín	goma nitrilica	воздушная камера	нитрильная резина

IMOVILLI POMPE SRL

Via Masaccio, 1 – Zona Industriale Mancasale – 42124 Reggio Emilia – Tel. +39 0522 516595 – Fax +39 0522 514735

[www.imovillipompe.it](http://www.imovillipompe.it) - e-mail: [service@imovillipompe.it](mailto:service@imovillipompe.it)