

# IPG143

- 3 membrane semidrauliche, collettori esterni, parti a contatto coi liquidi in ghisa, valvola di regolazione incorporata o comando a distanza.
- 3 diaphragms semi-hydraulic, external manifolds, all parts in contact with liquids are in cast iron. Regulating valve incorporated or control assembly remote.
- 3 membranas semihidráulicas, colectores externos, partes en contacto con líquidos en fundición. Válvula reguladora incorporada o mando a distancia.
- 3 membranes semi-hydrauliques, clavatures externes au carter, les parties en contact avec le liquide sont en fonte, vanne de régulation incorporée ou groupe de commande à distance.
- Pumpe in Sternbauweise mit 3 halb-hydraulisch Kolben-Membranen gestützt. Aussenliegende Saug-Druckkanäle. Flüssigkeitsführende Teile aus Gußeisen rostfrei. Regelventil angeflanscht oder Fernbedient.



## IMPIEGHI

Irrorazione, atomizzatori.

## APPLICATIONS

Spraying, mistblowers.

## APLICACIONES

Pulverización, atomizadores.

## EMPLOIS

Pulvérisation, atomiseurs.

## VERWENDUNGEN

Spritzen, Sprüngeräte.

COMPONENTI	MATERIALI	COMPONENTS	MATERIALS	COMPONENTES	MATERIALES	COMPOSANTS	MATERIAUX	TEILE	MATERIALEN
carter	ghisa	pump body	cast iron	cuerpo bomba	fundición	carter	fonte	Gehäuse	Grauguss
testata	ghisa	pump head	cast iron	culata	fundición	culasse	fonte	Zylinderkopf	Grauguss
collettori	ghisa	manifolds	cast iron	colectores	fundición	clavatures	fonte	Saug-Druckkanälen	Grauguss
valvola a-m.	acciaio inox	check valve	stainless steel	válvula a-m.	acero inox	clapet asp. ref.	acier inox	Ventil	rostfreier Stahl
cappellotto valvola	resina sintetica	valve cage	synthetic resin	cajara válvula	resina sintética	cage du clapet	resine synthétique	Ventilkäfig	Kunstharz
membrana	* gomma nitrilica	pump diaphragm	* nitril rubber	membrana	* goma nitrilica	membrane	* caoutchouc nitrilique	Membrane	* Gummi
camera aria	* gomma nitrilica	dumper diaphragm	* nitril rubber	membrana calderin	* goma nitrilica	chambre à air	* caoutchouc nitrilique	Windkesselmembrane	* Gummi
albero	acciaio cement. e temprato	pump shaft	casehardened steel	cigüeñal	acero cement. y templado	vilebrequin	acier cementé et trempé	Kurbelwelle	gehärteter Stahl

\* OPTIONAL DESMOPAN

\* OPTIONAL DESMOPAN

\* OPTIONAL DESMOPAN

\* OPTIONAL DESMOPAN

\* OPTIONAL DESMOPAN

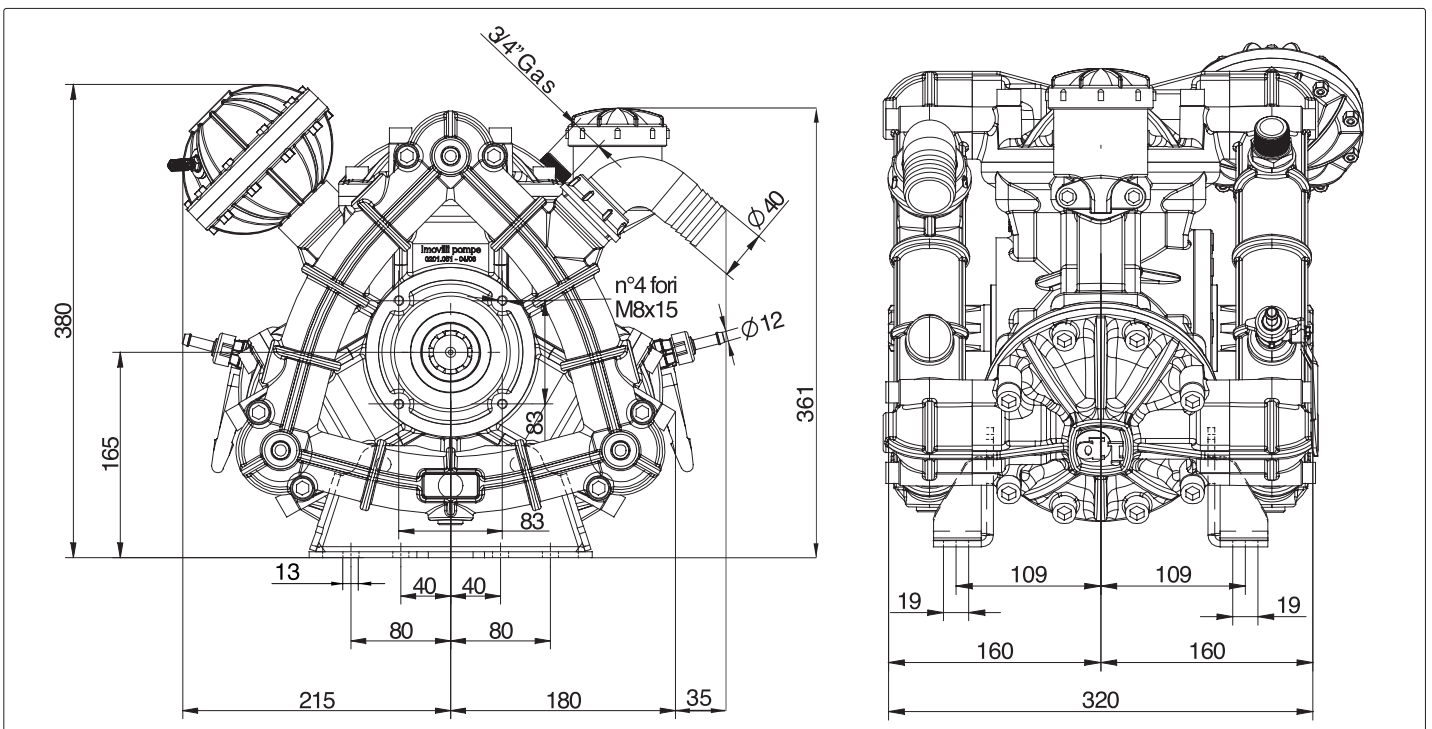

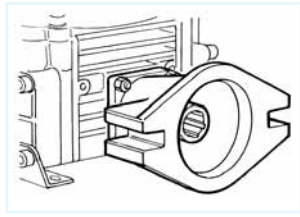

Kit flangiatura motore idraulico  
 Adapter flange kit for hydraulic motor  
 Brida para motores hidráulicos  
 Bride pour moteur hydraulique  
 Geflanscht zu Hydromotoren

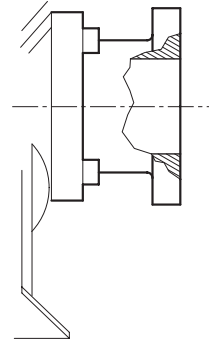

Flangia moltiplicatore  
 Flange for overgears  
 Brida para multiplicadora  
 Bride pour multiplicateur  
 Kupplungsflansch für Übersetzungsgetriebe

## VERSIONI

Albero passante M. 1"3/8 - M. 1"3/8, motopompe. Riduttore

## VERSIONS

Through shaft M. 1"3/8 - M. 1"3/8, pump sets. Gearbox

## VERSIONES

Eje pasante estriado M. 1"3/8 - M. 1"3/8, motobombas. Reductora

## VERSIONS

Arbre traversant cannelé môle 1"3/8, motopompes. Réducteur

## AUSFÜHRUNGEN

Durchgehender Gelenkwellenstummel 1"3/8 - 6 teilig beiderseits, Motorpumpen. Untersetzungsgetriebe

## USG LT/1'

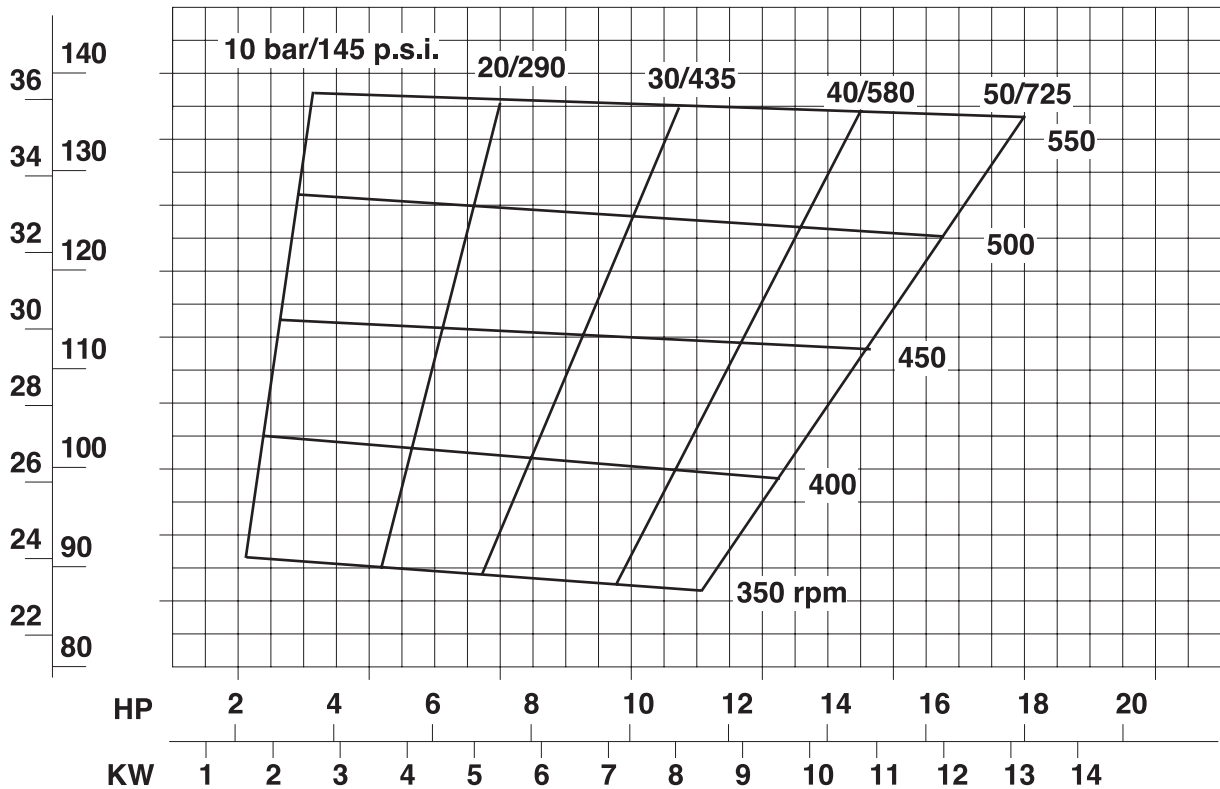

Giri/1': max 550  
 Pressione: max 50 BAR  
 Portata: max 140 lt/1'  
 Peso: kg 65  
 Max. disl. asp.: mt 3

Max RPM: 550  
 Pressure: max 50 BAR  
 Capacity: max 140 lt/1'  
 Weight: kg 65  
 Max suction lift: mt 3

RPM max: 550  
 Presión: max 50 BAR  
 Caudal: max 140 lt/1'  
 Peso: kg 65  
 Max disn. asp.: mt 3

Tours/1' max: 550  
 Pression: max 50 BAR  
 Débit: max 140 lt/1'  
 Poids: kg 65  
 Max haut, asp.: mt 3

Umdr. pro Minute: max 550  
 Druck: max 50 BAR  
 Förderstrom: max 140 lt/1'  
 Gewicht: kg 65  
 Max Ansaughöhe: mt 3

DATI INFORMATIVI

INDICATIVE DATA

DATOS INDICATIVOS

DONNÉES À TITRE D'INFORMATION

KENNDATEN UNVERBINDLICH



# imovilli pompe S.r.l.

Via Masaccio, 1 Zona Industriale Mancasale - 42010 Reggio Emilia Italy Tel. +39 0522 516595 Fax +39 0522 514735  
[www.imovillipompe.it](http://www.imovillipompe.it) • e-mail: [info@imovillipompe.it](mailto:info@imovillipompe.it)